

**Diaphragm valve T4**  
[direct pneumatic actuated]

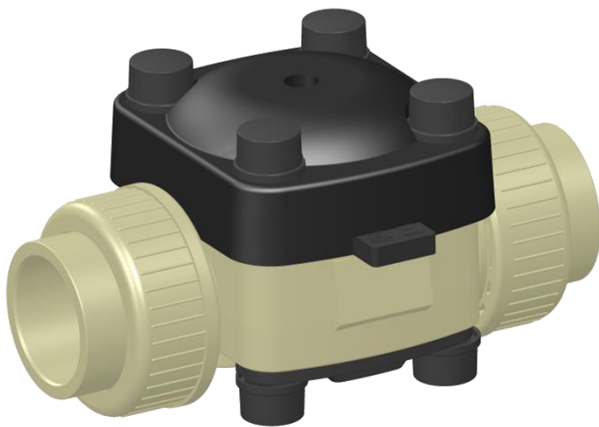
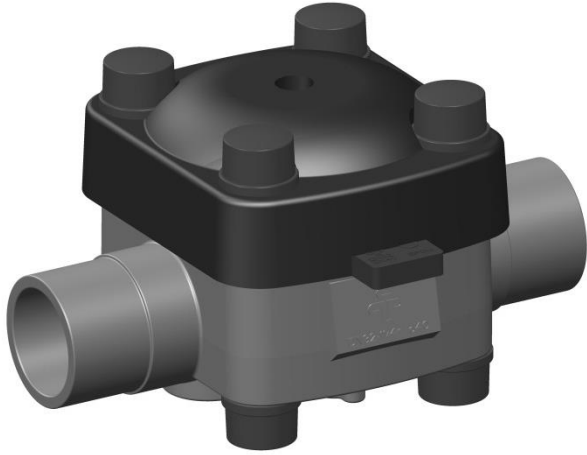

**General:**

- Body material: PVC-U, PP
- Seals: EPDM, FPM
- Diaphragm: EPDM, FPM
- Dimensions: DN15 – DN50  
d20 – d63  
1/2" – 2"

**Connections:**

- Union / Solvent socket  
PVC-U                      DIN / ASTM
- Solvent spigot  
PVC-U                        DIN
- Union / Fusion socket  
PP                             DIN
- Fusion spigot  
PP                             DIN

**Operating pressure:**      PN 6

**Technical features:**

- opening due to medium pressure, therefore easy assembly
- corrosion resistant
- long working life
- suitable for aggressive and dirty media
- radial installation or removal
- easy replacement of the diaphragm
- connection G 1/4" for direct screw in of a solenoid valve or a pneumatic couple

**Accessories:**

- 3/2 solenoid valve

This document does not constitute a guarantee, it is for initial information purposes only. The product range is constantly upgraded therefore the designs and types only reflect the state of the art at the time of printing.

**Diaphragm valve T4**  
[direct pneumatic actuated]

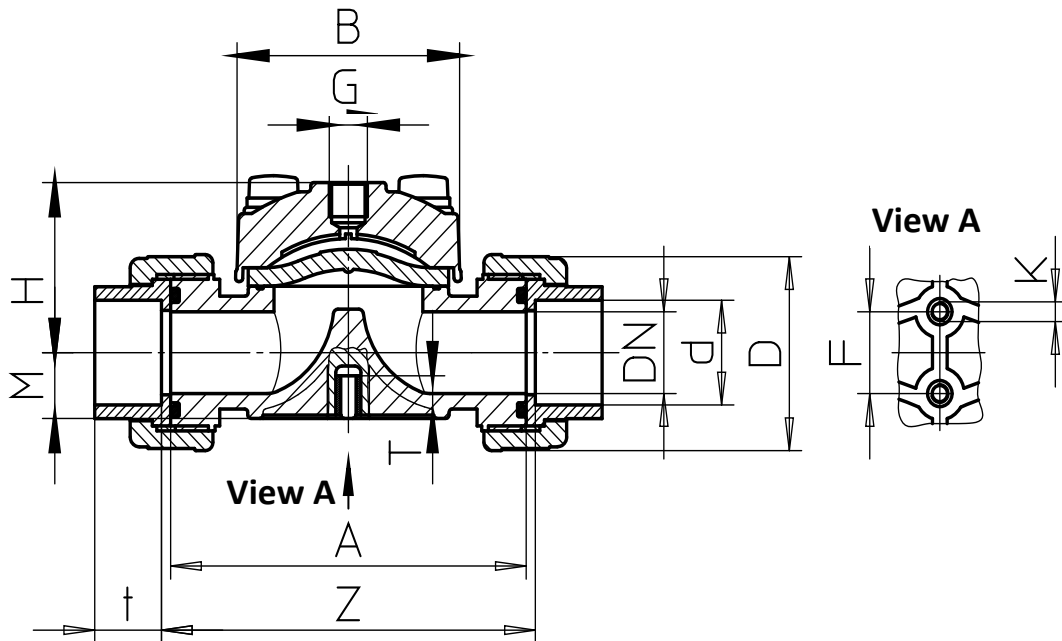

**PVC-U / PP**

**Connector type**

PVC-U union / solvent socket

PP union / fusion socket

DN	15	20	25	32	40	50
d	20	25	32	40	50	63
inch	½"	¾"	1"	1 ¼"	1 ½"	2"
A	90,0	108,0	116,0	136,0	154,0	184,0
B	64,0	64,0	74,0	101,0	101,0	117,0
D	43,0	53,0	60,0	74,0	83,0	103,0
F	25,0	25,0	25,0	45,0	45,0	45,0
G	¼"	¼"	¼"	¼"	¼"	¼"
H	47,0	47,0	53,0	70,0	70,0	78,0
K	M6	M6	M6	M8	M8	M8
M	17,0	17,0	21,0	33,0	33,0	40,5
t (PVC)	16,0	19,0	22,0	26,0	31,0	38,0
t (PP)	16,0	17,0	19,5	22,0	25,0	29,0
T	12,0	12,0	12,0	15,0	15,0	15,0
Z	96,0	114,0	122,0	142,0	160,0	190,0

Dimensions in mm

**Diaphragm valve T4**  
[direct pneumatic actuated]

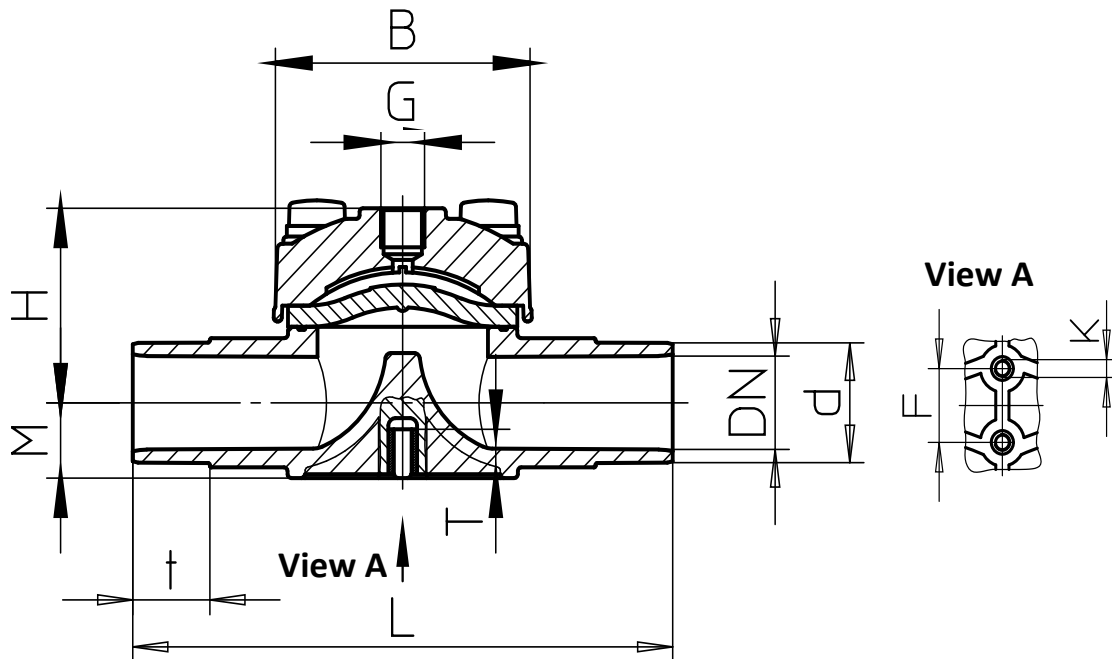

**PVC-U / PP**

**Connector type**

PVC-U solvent spigot

PP fusion spigot

DN	15	20	25	32	40	50
d	20	25	32	40	50	63
inch	½"	¾"	1"	1 ¼"	1 ½"	2"
B	64,0	64,0	74,0	101,0	101,0	117,0
F	25,0	25,0	25,0	45,0	45,0	45,0
G	¼"	¼"	¼"	¼"	¼"	¼"
H	47,0	47,0	53,0	70,0	70,0	78,0
K	M6	M6	M6	M8	M8	M8
L	124,0	144,0	154,0	174,0	194,0	224,0
M	17,0	17,0	21,0	33,0	33,0	40,5
t (PVC)	16,0	19,0	22,0	26,0	31,0	38,0
t (PP)	16,0	17,0	19,5	22,0	25,0	29,0
T	12,0	12,0	12,0	15,0	15,0	15,0

Dimensions in mm

# Diaphragm valve T4

[direct pneumatic actuated]



### Exploded drawing

- 01. Pneumatic top
- 02. Diaphragm
- 03. Spigot
- 04. Shim
- 05. Screw
- 06. Cover
- 07. O-Ring
- 08. Socket
- 09. Union nut
- 10. Hex nut

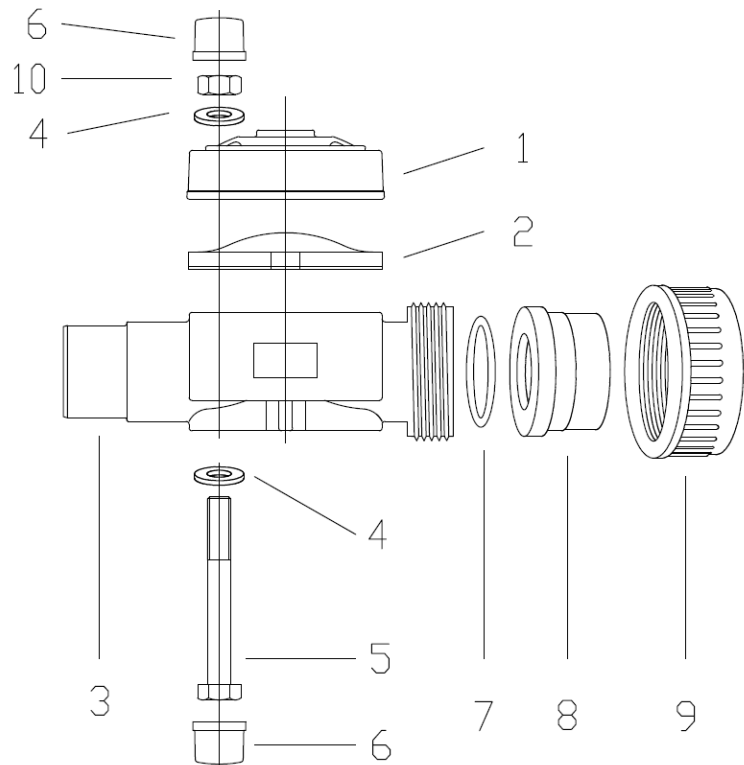

### Flow - Pressure loss diagram

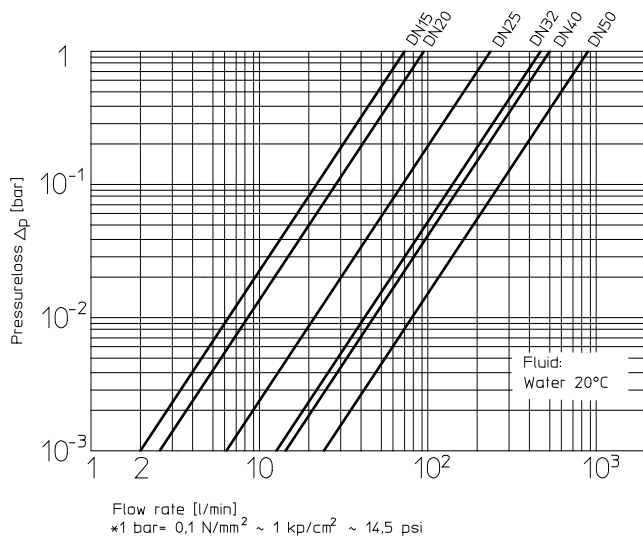

### Pressure - Temperature diagram PVC-U and PP

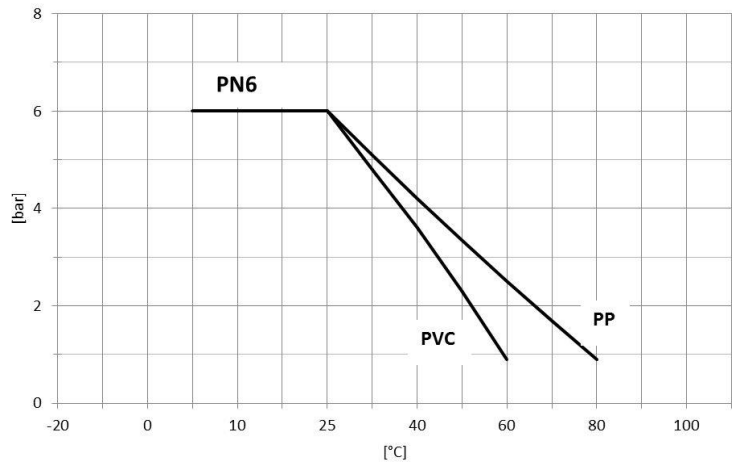

### Cv value table

Pressure loss	DN15	DN20	DN25	DN32	DN40	DN50	DN65	DN80	DN100	DN125
1 bar	70 l/min	95 l/min	250 l/min	450 l/min	500 l/min	880 l/min	1.100 l/min	1.700 l/min	2.700 l/min	4.000 l/min

## Diaphragm valve T4 [direct pneumatic actuated]

### Emptying of diaphragm valves

In order to achieve the optimum emptying of the diaphragm valve in horizontal mounted piping systems, we recommend the installation of the diaphragm valve according to the respective angle of rotation and an installation down-grade about 2°.

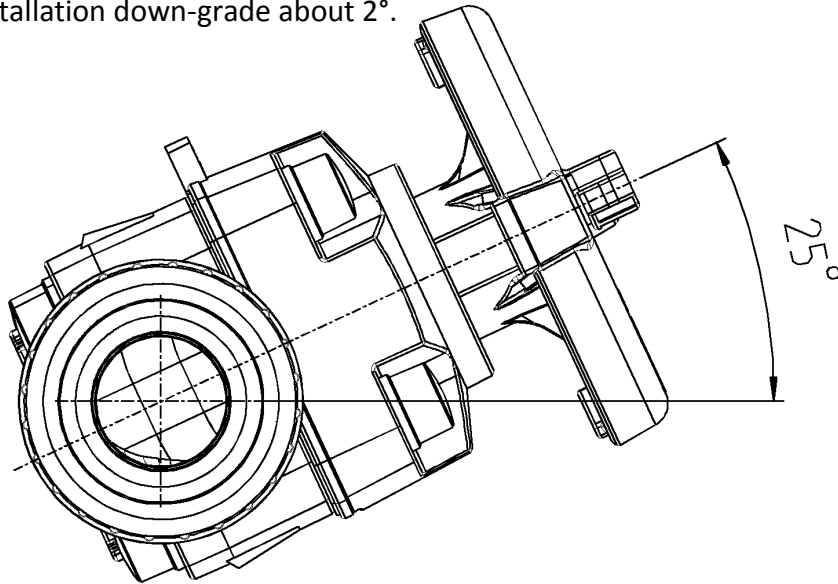

### Control pressure – Operating pressure – Diagram

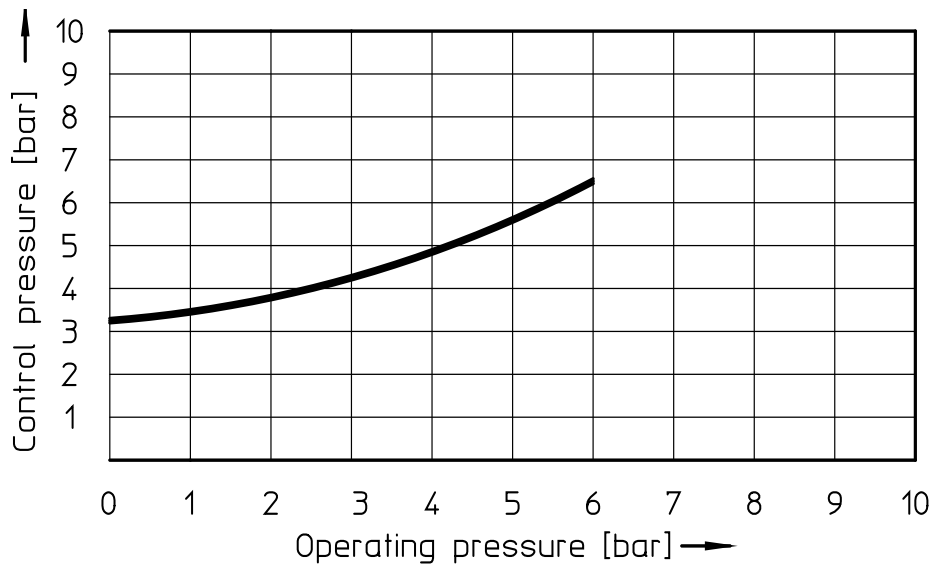

## Diaphragm valve T4 [direct pneumatic actuated]

### Note

- ⇒ To protect the diaphragm do not choose the control pressure higher than necessary (see diagram above)!
- ⇒ Due to the direct actuated diaphragm, the operating pressure of the diaphragm valve is PN6 and not PN10 as stated at the diaphragm body!

### Accessories:

#### 3/2 SOLENOID VALVE

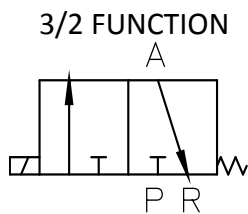

#### General

- Solenoid valve with 3/2-way function and with standard coil
- Protection class IP65 with cable plug
- Emergency manual override
- Service port G ¼" and plug-in connector Ø6mm

#### Material

- Body: Polyamide (PA)
- Bolt: Brass nickel plated
- Seal: NBR

#### Power Supply:

- 24 V DC      Item no. 50063
- 230 V AC     Item no. 50050